

## RCD300M2 Differential Current Relay



The RCD300M2 residual current relay is designed to provide sensitive ground fault protection without the problems associated with high-sensitivity nuisance tripping. It operates continuously and has the unique feature of a metering output to drive either a remote meter or interface with a PLC. This output signal gives the RCD300M2 both protective and predictive capabilities. By using it, leakages can be seen as they occur and ground faults can be detected before they become critical.

The RCD300M2 operates in conjunction with a Littelfuse WKE Series current transformer. The combination of the RCD300M2 measuring signal and the output signal from the WKE provide the required resilience to electrical noise - the main cause of nuisance tripping.

The RCD300M2 can operate on grounded, high-resistance grounded and ungrounded power systems. When a ground fault occurs, the RCD300M2 operates the leakage current output relay after the preset time delay. The RCD300M2 also continuously checks the connection to the C.T. If the C.T. circuit is broken, the RCD300M2 indicates "C.T. Fault" and operates the output relay. Due to its sensitivity, the RCD300M2 provides a high degree of network protection and personnel safety as well as minimizing the risk of fire.

### Features/Benefits

- Adjustable sensitivity of 10 mA to 3.0 A reduces nuisance trips.
- Adjustable time delay of 0-1.5 sec adapts to unique applications.
- Metering output with PLC interface for ease of continuous monitoring of system.
- Transformer continuity test allows immediate assurance of a safe system
- C.T. Loop Monitoring
- Harmonic Filtering
- DIN Standard molded case for ease of mounting via snap on rail or screw mounting.

### Applications

Ground fault relays can be used for the protection of critical circuits in applications such as panel boards and switch boards, OEM power distribution panels and custom controls. Additional applications include electric vehicle charging systems, wastewater treatment plants, marinas, pools and spas.

### Maintenance

The RCD300M2 requires no special maintenance procedures. Regular operation of the test features at suitable intervals and cleaning of the external parts are sufficient.

## Pure ac and pulsed ac/dc Systems

The RCD300M2 will work on both ac and pulsed ac/dc systems detecting even dc ground faults on the load side of the rectifier.

## Construction

The RCD300M2 comes in a DIN standard molded case suitable for snap-on rail mounting or for screw mounting.

## Operation

The RCD300M2 operates with a range of current transformers which come in diameters ranging from 1" to 81/4". The output relay and the alarm indicator on the front cover are adjustable internally for hand or automatic reset. In the hand reset mode, a remote reset button may be used.

The test facility on the RCD300M2 may be actuated locally or remotely. It electronically tests both the current transformer loop continuity and the output relay operation.

## Mounting and Wiring

The RCD300M2 can be either DIN rail mounted or fixed to a panel using 2 screw holes at the device corners. Terminals are clearly marked for connection.

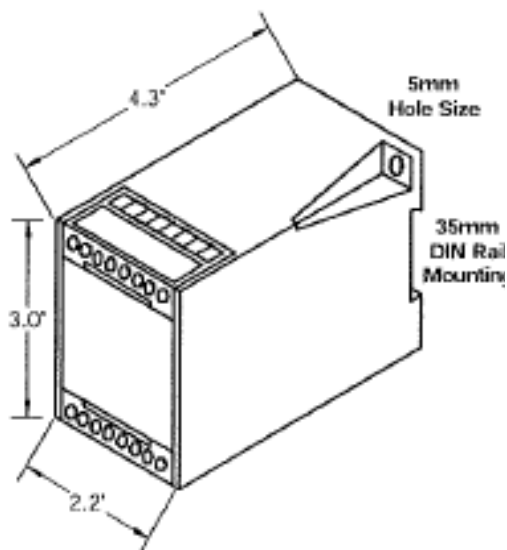

## Auxiliary Supply

The RCD300M2 requires an auxiliary supply voltage of 24V ac/dc or 120V, 50/60 Hz. The unit can also be ordered to operate with other power supplies.

## Transformer Continuity Test

The RCD300M2 continuously monitors the connection to the CT. If this loop is broken the output relay is operated and the "C.T. FAULT" LED provides immediate indication of the front panel. The test button S1 is used to electronically interrupt this cycle as a means of testing the function.

A remote test button S5 (single pole, normally-open spring return) may also be installed in series with the external C.T. wiring.

## Time Delay Adjustment

The RCD300M2 time response is continuously adjustable from 0-1.5 seconds by a potentiometer on the front plate.

## Trip/Alarm Output Relay

Two sets of changeover trip/alarm contacts are provided, rated at 250V, 5A. This allows one set to be used for tripping and the other set for remote indication.

Under FAILSAFE operating conditions, the relay coil is energized with Terminals 12-13 and 14-15 closed (FAILSAFE MODE). The action may be reversed (ACTIVE MODE) by adjusting switch S3 located behind the front plate. In the ACTIVE mode the relay coil is energized only when a group fault occurs.  
Switch S3: **CLOSED = ACTIVE** **OPEN = FAILSAFE**

## Metering Output

The RCD300M2 has a continuous metering output to drive either a remote meter or interface with a PLC. The output signal is 0 – 1mA and is proportional to 0 – 100% of the relay trip response rating.

## Leakage Current Response Adjustment

Leakage current response adjustment has a 10 position fixed point selector switch adjustable from 10mA to 3.0 Amps

## Local Alarms

In addition to the trip relay there are 3 LED indicators on the front cover. The green LED is for "POWER ON", the upper red LED indicates "LEAKAGE CURRENT" and the lower red LED indicates a C.T. FAULT

# Ground Fault Relays



Expertise Applied | Answers Delivered

## Specifications

Nominal AC insulation Voltage	500 V AC
Insulation Ground t UL 508	Class C
VDE 0110 Test voltage	2000 V AC
Operation Class	Continuous
Supply voltage Vs	24V ac/dc or 120V, 50-60 Hz
Maximum self consumption	4VA
Alarm Relay Contacts	2 volt-free NO/NC
Switching capacity	1100VA
Rated Contact voltage	250V
Continuous Current	5 A
Breaking Capacity	
@240V AC P.F. = 0.4	3 A
@ 110VDC, @L/R = 0	0.3 A
Relay Function Selection	
Adjustable Function	Failsafe/Active
Relay Alarm Memory	Hand/Auto Reset
Factory Settings	Auto Reset
Leakage Current Response Range	10/30/60/80/100/ 300/600/800mA, 1.0/3.0A
Time Delay	0 - 1.5 secs
Operating Ambient Temp.	-10 to +60 deg. C
Storage Ambient Temp.	-40 to +80 deg. C
Mounting	
Terminal Capacity	0.5 to 5 mm 2.
Weight	.73 lbs
CT Type WKE	1" to 8.25" dia.
(see Chart)	

### WKE Series Current Transformer

There are 7 diameters of C.T.s ranging from 1" to 8 ¼". The C.T. is connected across terminals 7 and 8. It is essential when installing C.T.s that only the load cable conductors L and N (1PH) or L1, L2, and L3 with N, if used (3ph, 3 or 4 wire), are passed through the center of the C.T. The ground wire must remain outside the C.T. core.

Part Number	Internal Diameter
WKE 25*	1"
WKE 35	1 3/8"
WKE 60*	2 1/3"
WKE 95*	3 ¾"
WKE 130*	5 1/8"
WKE 200*	8"
WKE 210	8 ¼"

\* High Current Applications

## Wiring Diagrams

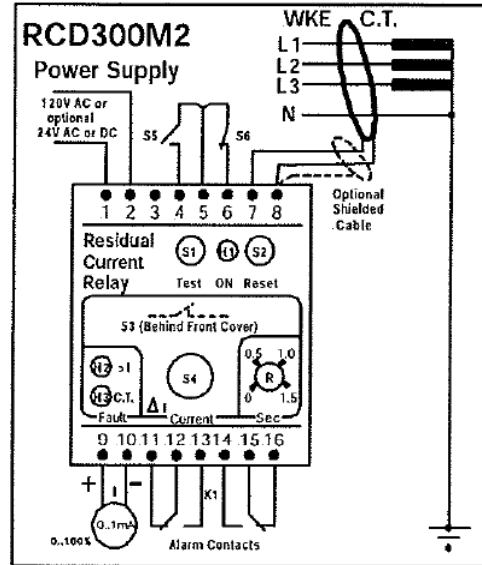

H1	LED green "POWER ON"
H2	LED red "LEAKAGE CURRENT"
H3	LED red "C.T. FAULT"
S1	TEST button
S2	RESET button
S3	FAILSAFE/ACTIVE Located behind front plate "Closed" = Active "OPEN" = Failsafe
S4	Leakage current selector switch
K1	Relay for alarm
R	Time delay potentiometer
S5	External test button (optional)
S6	External reset button (optional)
I	External meter for leakage current
1-2	Input power supply 24V ac/dc or 120VAC
7-8	C.T. connections
5-6	Auto/Hand reset selections

## WKE Series Current Transformers

The WKE Series of current transformers is a key component of the POWR-GARD ground fault detection product line. These CTs are highly accurate. They convert very small differential currents to an ac voltage and output this signal to the connected POWR-GARD ground fault relay. The WKE Series CTs are made from high-density mu metal which has unique and repeatable output characteristics.

### Features

The WKE CTs have built-in safety features far surpassing those of CTs with a ferrite core. The WKE CT is resistant to open circuit burn out and will saturate at safe, low-level voltages. The CTs are housed with an insulating protection. They have built in brackets to facilitate mounting. Terminal cover may be wire sealed for further protection

<b>Primary Current</b>	<b>2500A</b>
<b>Secondary Current</b>	<b>350mA</b>
<b>NSV</b>	<b>600Vac</b>
<b>BIL Rating</b>	<b>2000V</b>
<b>Rated Frequency</b>	<b>10 – 1000Hz</b>
<b>Thermal current rating</b>	<b>70° C</b>
<b>No Fixed Burden</b>	
<b>Accuracy</b>	<b>99%</b>
<b>Flux Shielding</b>	

### Installation Instructions

When installing the WKE CTs, ensure the following:

1. Only the load carrying conductors pass through the center of the CT. (This means L1 + N for 1 phase and L1+ L2 + L3 for 3 phases.)
2. The power conductors pass through the center of the CT and are preferably bound together to keep the conductors uniformly spaced.
3. The power conductors pass PERPENDICULAR to the CT and, whenever practical, continue perpendicular to the CT on both sides of the CT for 3".
4. The power conductors should not be installed in a way that allows them to run along the side edges of the CT.
5. Whenever practical, locate the CT away from noise-generating devices such as transformers, frequency converters, etc.

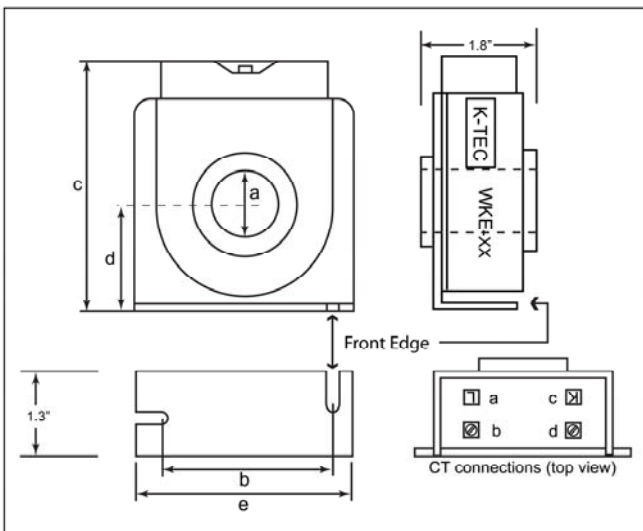

### Dimensions (in)

	a	b	c	d	e
<b>WKE 25</b>	1	3	3.9	1.63	3.63
<b>WKE 60</b>	2.36	3.9	5.25	2.37	4.50
<b>WKE 95</b>	3.74	5.5	6.9	3.25	6.25
<b>WKE130</b>	5.12	7.25	8.5	4	7.0
<b>WKE 200</b>	8.0	10.4	12.1	6.0	11.4