

IXYF20N400C

4000 V, 13 A High Voltage XPT™ IGBT

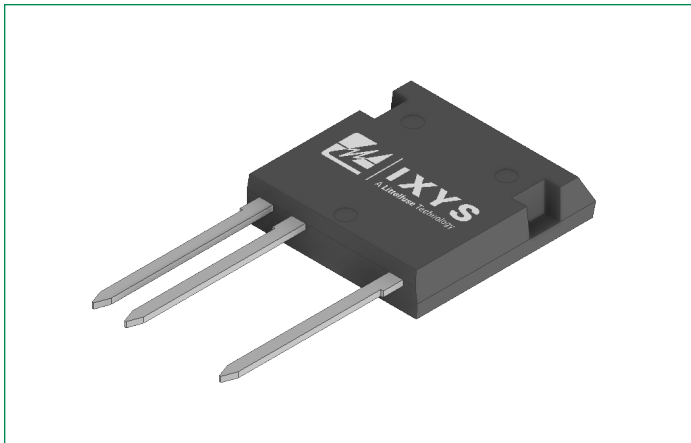

Description:

Designed using the proprietary XPT™ technology and state-of-the-art IGBT process, these devices feature high blocking voltage, switching robustness, and low energy loss.

Features & Benefits:

- Silicon Chip on Direct-Copper Bond (DCB) Substrate
- Isolated Mounting Surface
- 4000V~ Electrical Isolation
- High Peak Current Capability
- Fast Switching
- Low Gate Drive Requirement
- High Power Density

Applications:

- Switch-Mode and Resonant-Mode Power Supplies
- Uninterruptible Power Supplies (UPS)
- Laser Generators
- Capacitor Discharge Circuits
- AC Switches

Product Summary

Characteristic	Value	Unit
V_{CES}	4000	V
I_{C110}	13	A
$V_{CE(sat)}$	3.2	V

Pinout Diagram (ISOPLUS i4-Pak™)

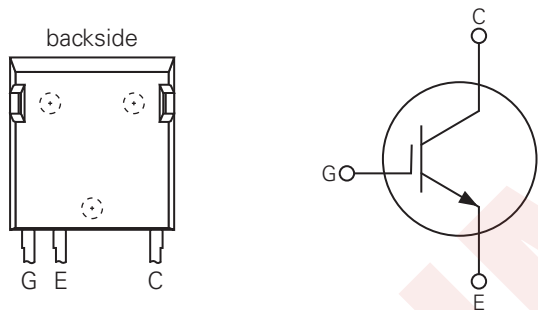

G: Gate; **C:** Collector; **E:** Emitter; **backside:** Isolated

Maximum Ratings

Symbol	Characteristic	Conditions	Value	Unit
V_{CES}	Collector-Emitter Voltage	$T_J = 25^\circ\text{C}$ to 150°C	4000	V
V_{GES}	Gate-Emitter Voltage	Continuous	± 20	V
V_{GEM}	Transient Gate-Emitter Voltage	Transient	± 30	V
I_{C25}	Continuous Collector Current	$T_C = 25^\circ\text{C}$	29	A
I_{C110}	Continuous Collector Current	$T_C = 110^\circ\text{C}$	13	A
I_{CM}	Pulsed Collector Current	$T_C = 25^\circ\text{C}$, 1 ms	174	A
SSOA (RBSOA)	Switching Safe Operating Area (Reverse Biased Safe Operating Area)	$V_{GE} = 15\text{ V}$, $T_{VJ} = 125^\circ\text{C}$, $R_G = 10\ \Omega$, $I_{CM} = V_{CE} \leq 0.8 \times V_{CES}$	40	A
P_C	Collector Power Dissipation	$T_C = 25^\circ\text{C}$	190	W
T_J	Junction Temperature	–	-55 to 150	$^\circ\text{C}$
T_{JM}	Maximum Junction Temperature	–	150	$^\circ\text{C}$
T_{stg}	Storage Temperature	–	-55 to 150	$^\circ\text{C}$
V_{ISOL}	Isolation Voltage	50/60 Hz, 1 min	4000	V~
T_L	Lead Temperature for Soldering	1.6 mm (0.062 in.) from Case for 10 s	300	$^\circ\text{C}$
F_C	Mounting Force	–	20..120/4.5..27	Nm/lb.in
W	Weight	–	5	g

Thermal Characteristics

Symbol	Characteristic	Value			Unit
		Min.	Typ.	Max.	
$R_{th,JC}$	Thermal Resistance, junction-to-case	–	–	0.66	$^\circ\text{C}/\text{W}$
$R_{th,CS}$	Thermal Resistance, case-to-heat sink	–	0.15	–	$^\circ\text{C}/\text{W}$

Electrical Characteristics – Static ($T_J = 25^\circ\text{C}$ unless otherwise specified)

Symbol	Characteristic	Conditions	Value			Unit
			Min.	Typ.	Max.	
BV_{CES}	Collector-Emitter Breakdown Voltage	$I_C = 250\ \mu\text{A}$, $V_{GE} = 0\text{ V}$	4000	–	–	V
$V_{GE(th)}$	Gate-Emitter Threshold Voltage	$I_C = 1\text{ mA}$, $V_{CE} = V_{GE}$	3.0	–	5.0	V
I_{GES}	Gate-Emitter Leakage Current	$V_{CE} = 0\text{ V}$, $V_{GE} = \pm 20\text{ V}$	–	–	± 200	nA
I_{CES}	Zero Gate Voltage Collector Current ²	$V_{CE} = 0.8 \times V_{CES}$, $V_{GE} = 0\text{ V}$	–	–	50	μA
		$V_{CE} = 0.8 \times V_{CES}$, $V_{GE} = 0\text{ V}$, $T_J = 125^\circ\text{C}$	–	–	5	mA
$V_{CE(sat)}$	Collector-Emitter Saturation Voltage ¹	$I_C = 20\text{ A}$, $V_{GE} = 15\text{ V}$	–	3.2	4.2	V
		$I_C = 20\text{ A}$, $V_{GE} = 15\text{ V}$, $T_J = 125^\circ\text{C}$	–	3.7	–	V

Note 1: Pulse test, $t \leq 300\ \mu\text{s}$, duty cycle, $d \leq 2\%$

Note 2: Switching times and energy losses may increase for higher $V_{CE(clamp)}$, T_J , or R_G .

Electrical Characteristics – Dynamic ($T_J = 25^\circ\text{C}$ unless otherwise specified)

Symbol	Characteristic	Conditions	Value			Unit	
			Min.	Typ.	Max.		
g_{fs}	Transconductance ¹	$I_C = 20\text{ A}, V_{CE} = 10\text{ V}$	18	30	–	S	
C_{ies}	Input Capacitance	$V_{GE} = 0\text{ V}, V_{CE} = 25\text{ V}, f = 1\text{ MHz}$	–	2760	–	pF	
C_{oes}	Output Capacitance		–	87	–		
C_{res}	Reverse Transfer Capacitance		–	30	–		
$Q_{g(on)}$	Total Gate Charge	$V_{GE} = 15\text{ V}, V_{CE} = 2000\text{ V},$ $I_C = 20\text{ A}$	–	136	–	nC	
Q_{ge}	Gate-Emitter Charge		–	16	–		
Q_{gc}	Gate-Collector Charge		–	62	–		
$t_{d(on)}$	Turn-on Delay Time ²	Inductive Load, $V_{GE} = 15\text{ V},$ $V_{CE} = 1200\text{ V},$ $I_C = 20\text{ A},$ $R_{G(ext)} = 5\ \Omega$	$T_J = 25^\circ\text{C}$	–	13	–	ns
			$T_J = 125^\circ\text{C}$	–	14	–	
t_{ri}	Turn-on Rise Time ²		$T_J = 25^\circ\text{C}$	–	15	–	ns
			$T_J = 125^\circ\text{C}$	–	19	–	
E_{on}	Turn-on Energy ²		$T_J = 25^\circ\text{C}$	–	5.2	–	mJ
			$T_J = 125^\circ\text{C}$	–	6.0	–	
$t_{d(off)}$	Turn-off Delay Time ²		$T_J = 25^\circ\text{C}$	–	165	–	ns
			$T_J = 125^\circ\text{C}$	–	180	–	
t_{fi}	Turn-off Fall Time ²		$T_J = 25^\circ\text{C}$	–	190	–	ns
			$T_J = 125^\circ\text{C}$	–	140	–	
E_{off}	Turn-off Energy ²	$T_J = 25^\circ\text{C}$	–	2.5	–	mJ	
		$T_J = 125^\circ\text{C}$	–	2.4	–		

Note 1: Pulse test, $t \leq 300\ \mu\text{s}$, duty cycle, $d \leq 2\%$

Note 2: Switching times and energy losses may increase for higher $V_{CE(clamp)}$, T_J , or R_G .

Characteristic Curves

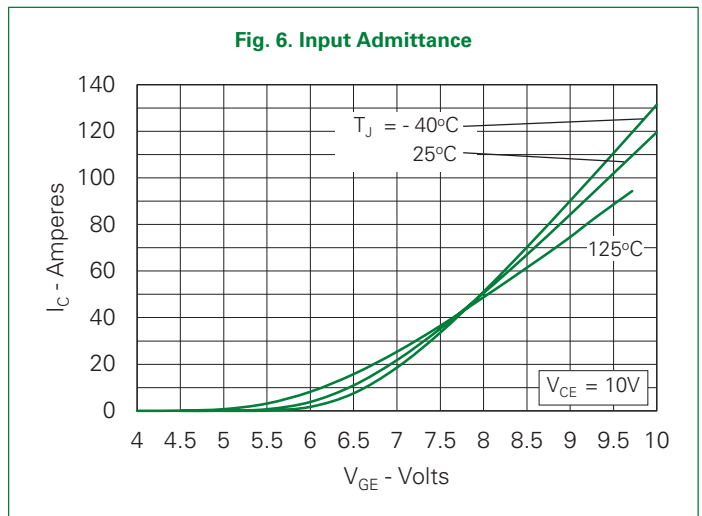
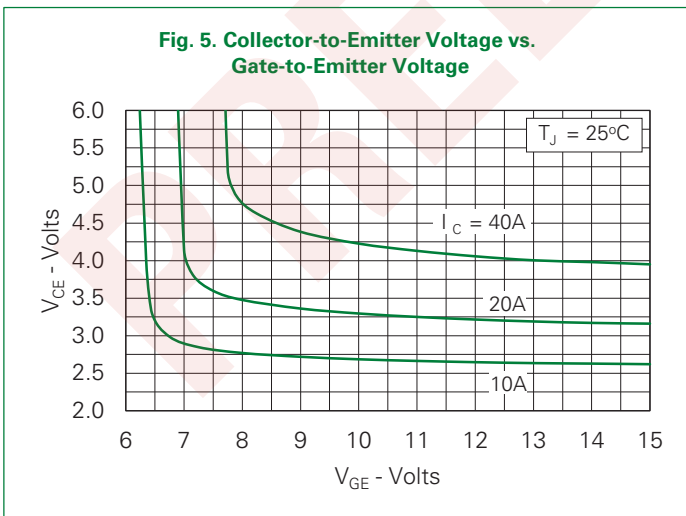
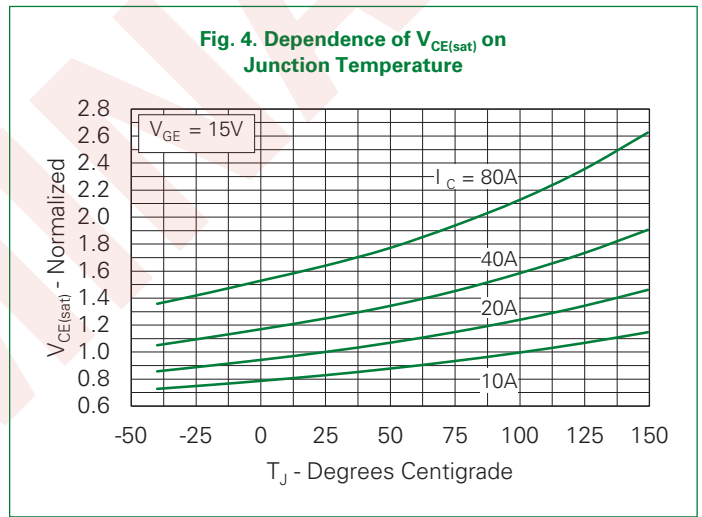
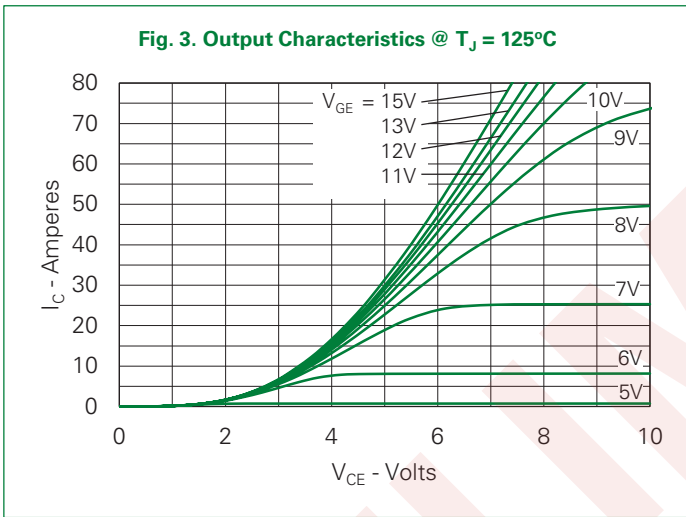
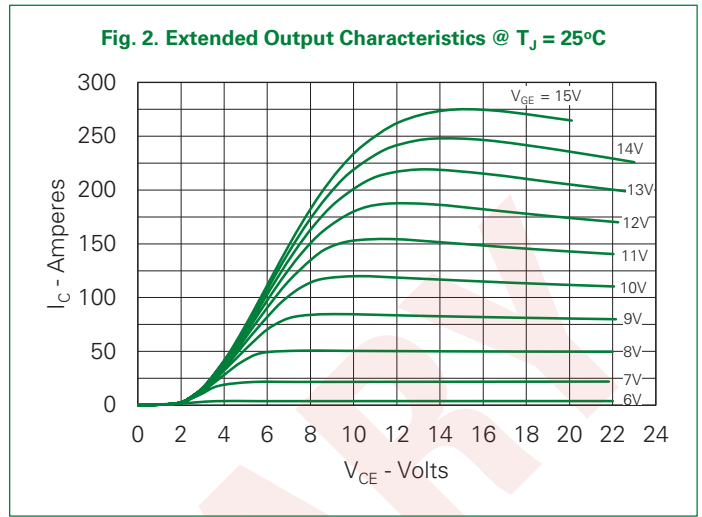
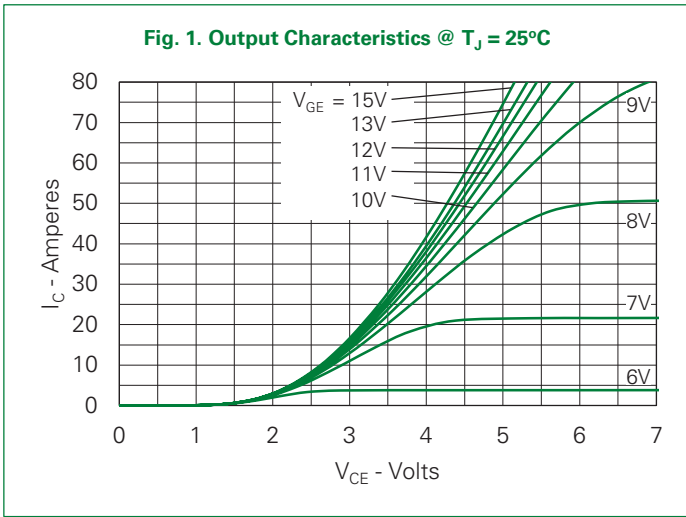

Fig. 7. Transconductance

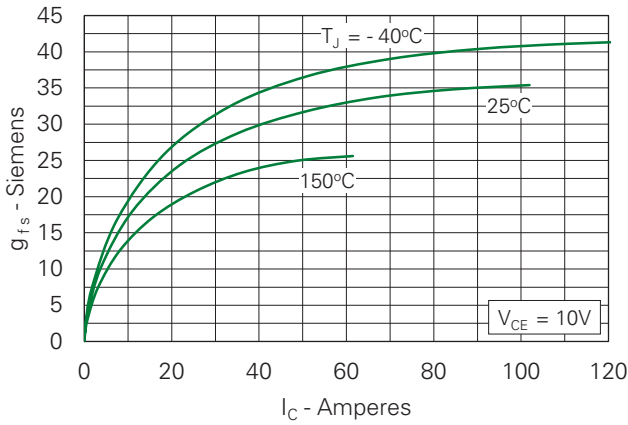

Fig. 8. Gate Charge

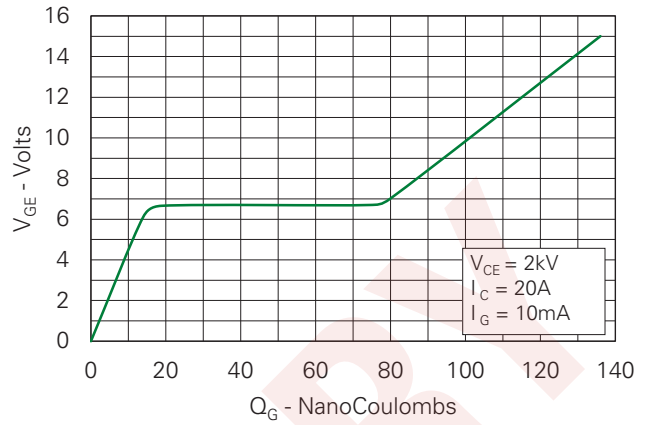

Fig. 9. Capacitance

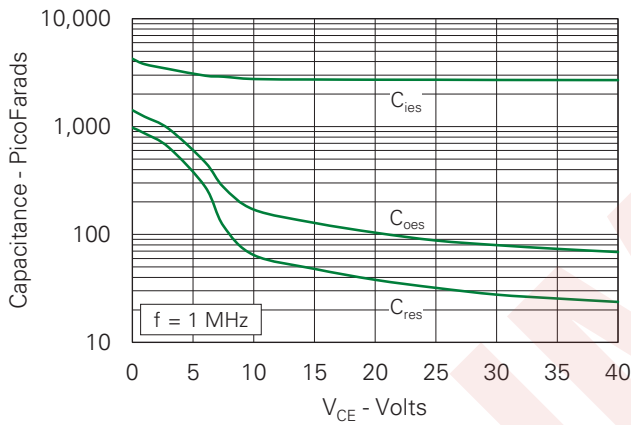

Fig. 10. Reverse-Bias Safe Operating Area

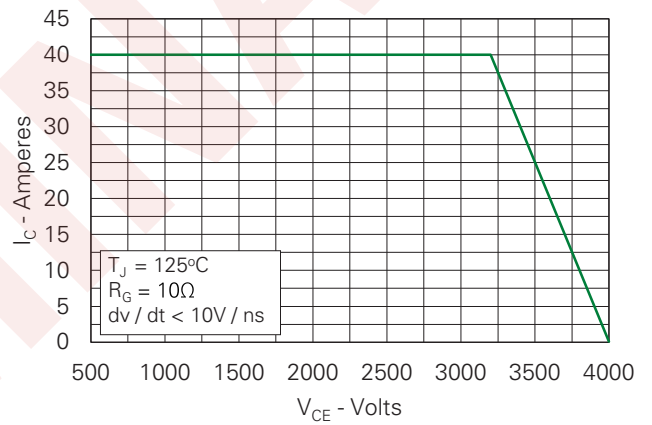

Fig. 11. Maximum Transient Thermal Impedance

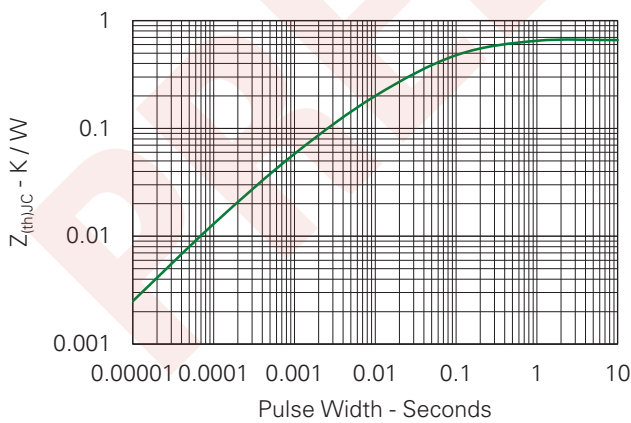

Fig. 12. Inductive Switching Energy Loss vs. Gate Resistance

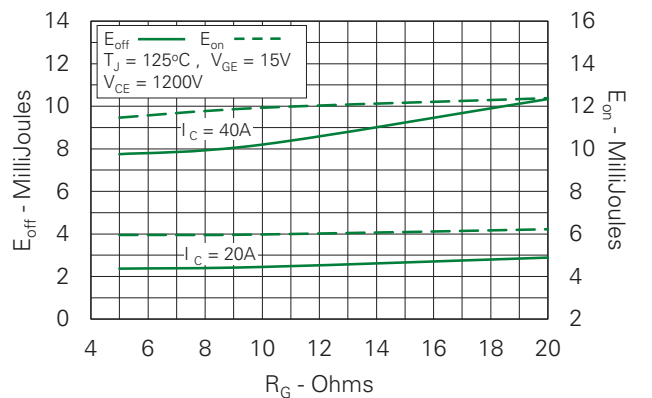

Fig. 13. Inductive Switching Energy Loss vs. Collector Current

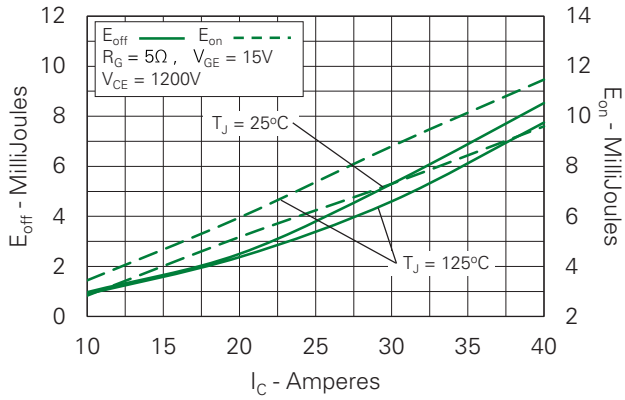

Fig. 14. Inductive Switching Energy Loss vs. Junction Temperature

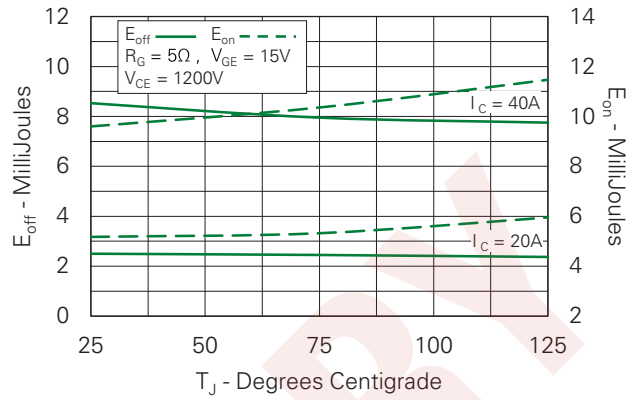

Fig. 15. Inductive Turn-off Switching Times vs. Gate Resistance

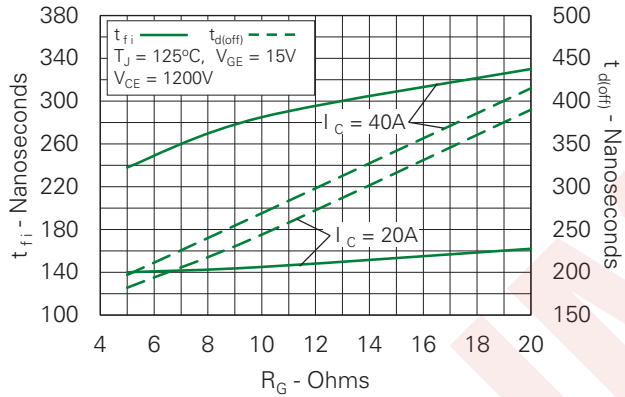

Fig. 16. Inductive Turn-off Switching Times vs. Collector Current

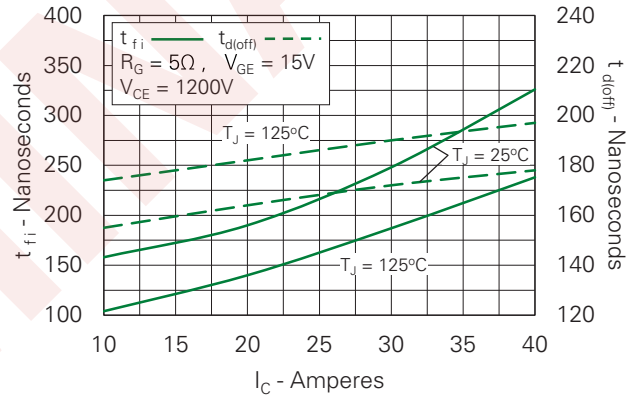

Fig. 17. Inductive Turn-off Switching Times vs. Junction Temperature

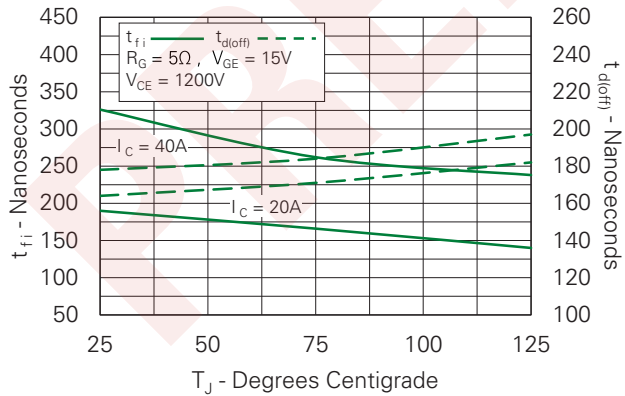

Fig. 18. Inductive Turn-on Switching Times vs. Gate Resistance

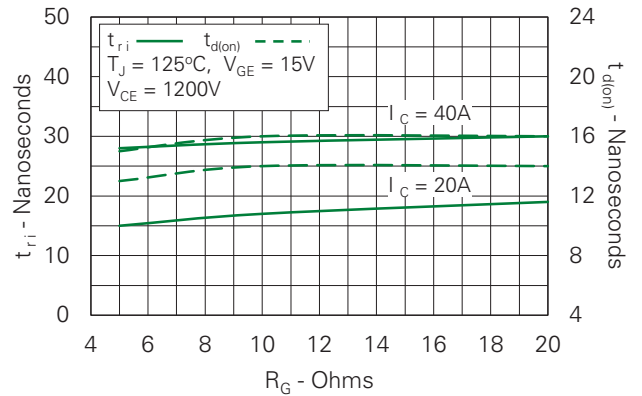

Fig. 19. Inductive Turn-on Switching Times vs. Collector Current

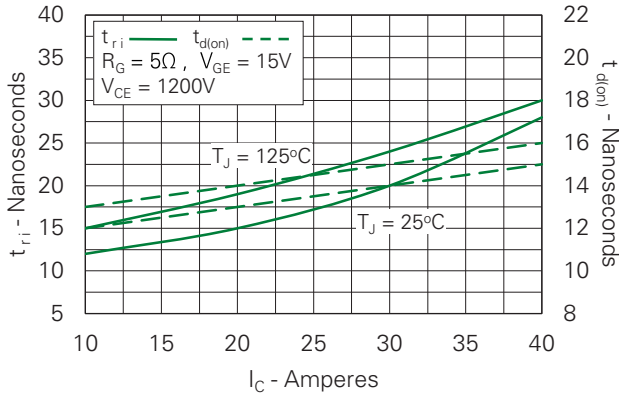
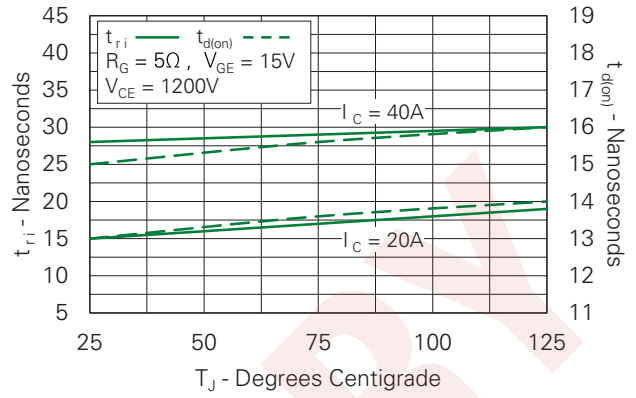
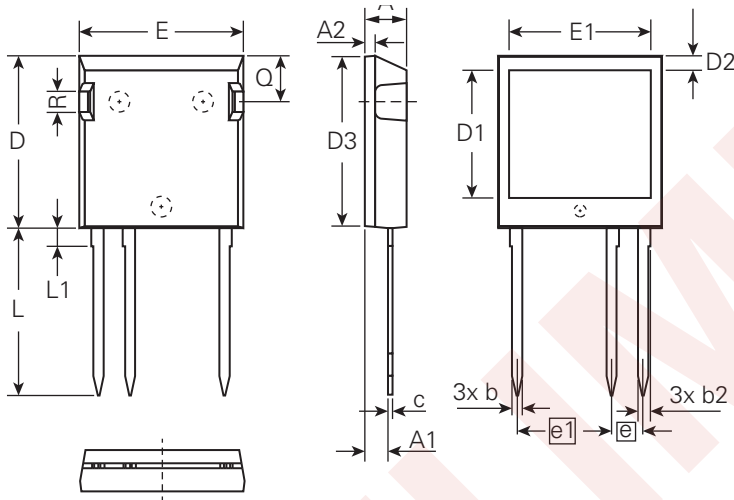

Fig. 20. Inductive Turn-on Switching Times vs. Junction Temperature



Part Outline Drawing (ISOPLUS i4-Pak™)



Symbol	Inches			Millimeters		
	Min.	Typical	Max.	Min.	Typical	Max.
A	0.190	-	0.205	4.83	-	5.21
A1	0.102	-	0.118	2.59	-	3.00
A2	0.046	-	0.085	1.17	-	2.16
b	0.045	-	0.055	1.14	-	1.40
b2	0.058	-	0.068	1.47	-	1.73
c	0.020	-	0.029	0.51	-	0.74
D	0.819	-	0.840	20.80	-	21.34
D1	0.590	-	0.620	14.99	-	15.75
D2	0.065	-	0.080	1.65	-	2.03
E	0.770	-	0.799	19.56	-	20.29
E1	0.660	-	0.690	16.76	-	17.53
e	0.150 BSC			3.81 BSC		
e1	0.450 BSC			11.43 BSC		
L	0.780	-	0.840	19.81	-	21.34
L1	0.083	-	0.102	2.11	-	2.59
Q	0.210	-	0.244	5.33	-	6.20
R	0.100	-	0.180	2.54	-	4.57

Disclaimer Notice - Information furnished is believed to be accurate and reliable. However, users should independently evaluate the suitability of and test each product selected for their own applications. Littelfuse products are not designed for, and may not be used in, all applications. Read complete Disclaimer Notice at <http://www.littelfuse.com/disclaimer-electronics>.